



NautoPilot® NP 60





NautoPilot® NP 60

The new NautoPilot® NP 60 has been specially designed for small ships. It is based on over 80 years of experience in automatic steering. This versatile autopilot offers highest precision in course and track control and gives best flexibility to fulfill your individual needs.

Highest precision and best flexibility

The NP 60 can be operated in heading control and track control. Due to the automatic adaptation of the ships speed and the built-in intelligence, the NP 60 caters for an efficient use of the steering gear reducing wear and fuel consumption. With the push of a button you can change between working modes – e.g. from transit to trawling. But the NP 60 will also assist you in manual steering.

With «Preset-Turn» predefined course changes are accomplished to port or starboard. This feature can be used during fishing to steer the ship in a meander-course.

Follow-up and non-follow-up tillers can be connected to the NP 60. These tillers are equipped with a take-over function to take over the control from the autopilot and vice versa.

For your safety

In an emergency situation a dodge manoeuvre can be performed directly from the NP 60 or via the follow-up and non-follow-up tillers. The point of control is always indicated in the display of the NP 60.

A watch alarm is user definable. It can be reset directly from the NP 60 or by use of a remote panel. An audible and visible alarm is given if the limits in heading or track control are exceeded or speed and heading sensor information are disturbed.



All important information at a glance

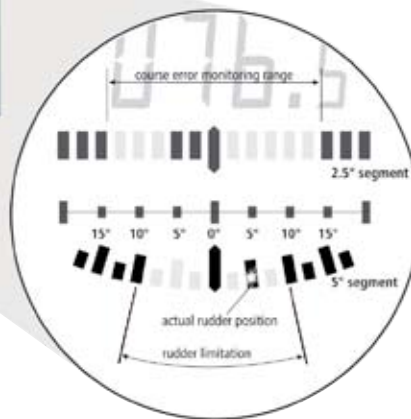

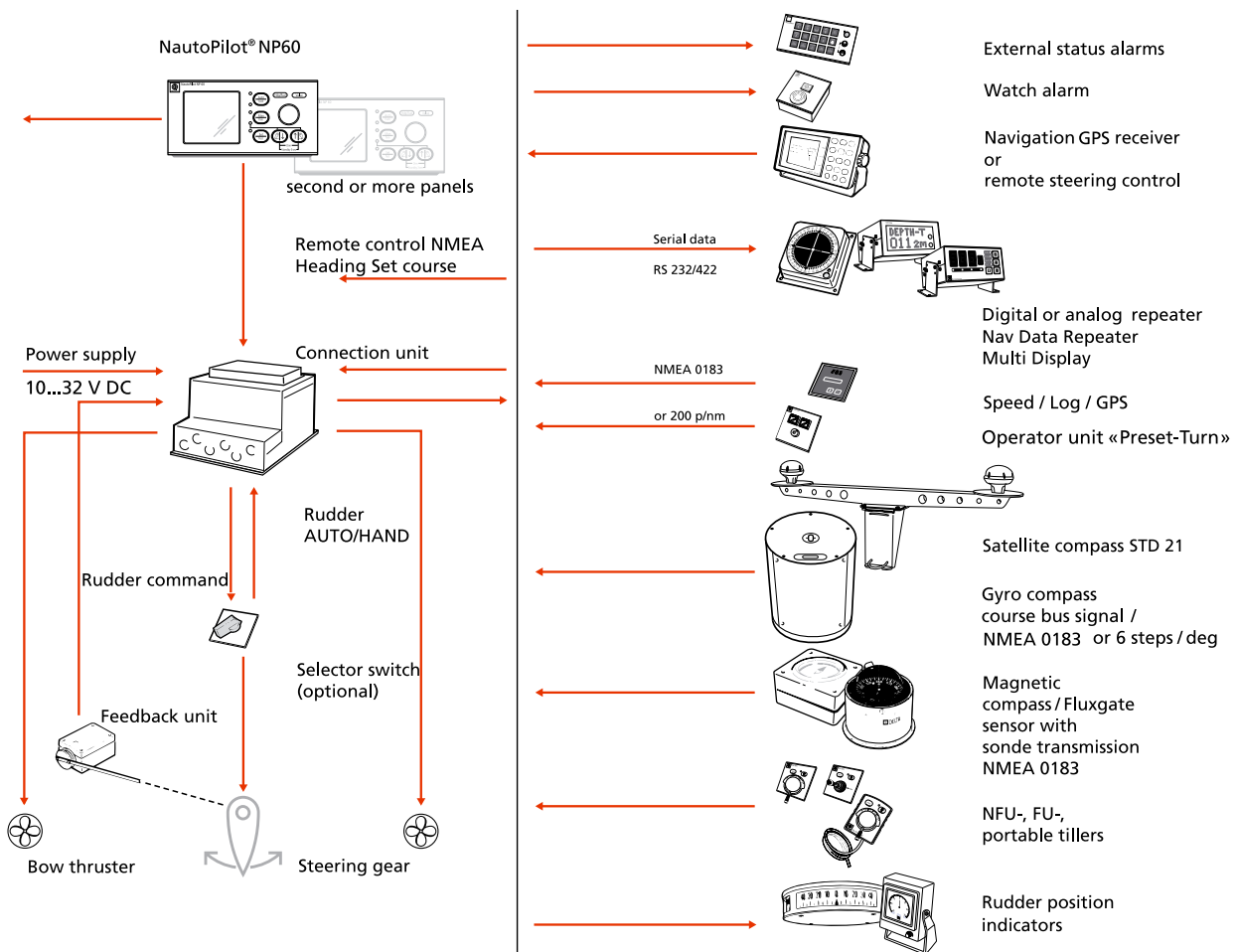

Approved for your ship

The NautoPilot® NP 60 can be used on ships with monohulls and on catamarans in combination with:

- Steering gears with switching and proportional solenoids
- Rudder propellers
- Twin-rudders
- Water jet drives and
- Bow thrusters

NautoPilot® NP 60 is type approved and in addition approved as a heading control system for standard and High-Speed Craft up to 70 knots both in accordance to the International Maritime Organisation (IMO) standards.

Accessories

A wide range of accessories are available to fulfill your individual needs:

- Remote autopilot operator units
- Analog and digital compass repeaters that can be directly connected to NP 60
- Follow-up and non-follow-up steering tillers with take-over function
- Rudder position indicators
- GPS receiver for track control (Autopilot sentence B of NMEA telegram format)
- Signal unit as remote alarm panel
- Remote watch alarm reset
- Remote «Preset-Turn» activation

Technical Data

Supply Voltage

24 V DC (10-32 V DC)

Power Consumption

Approx. 10 W

Signal Inputs

Gyro compass / satellite compass

- Course bus or NMEA telegrams HEHDT, GPHDT
- 6 steps per degree

Magnetic Compass

- NMEA telegrams HCHDT or HDM
- With magnetic compass sonde 108-010

Speed log

- NMEA telegrams VTG, VHW
- 200 pulses/nm

Position Receiver

- NMEA telegrams APB, APA

Remote control

- NMEA telegram HSC

Signal Outputs

Outputs to steering gear

- 2 switching outputs (24 V DC, max. 2.0 A)
- 2 analog outputs (+/- 10 V DC, max. 5 mA)

Monitoring/alarm outputs

- Off heading
- Off track
- Heading monitor
- Watch alarm

In accordance with

- EN/ISO 11674
- EN/IEC 60945
- NMEA according to EN/IEC 61162-1
- A.342 (IX), MSC 64/67 Annex 3, A.694 (17), A.813 (19) for High-Speed Craft:
- A.694 (17), A.813 (19), A.822 (19)

For details refer to EC-type examination certificate.

Type of enclosure acc. to IEC/EN 60529

- Operator unit IP 44 (option IP 56)
- Connection unit IP 22

General Data

Permissible ambient temperature

- Operation: -15° to 55°C (operator unit)
- 15° to 55°C (connection unit)
- Storage: -25° to 70°C (operator unit)
- 25° to 70°C (connection unit)

NautoPilot® is a registered trademark of Raytheon Anschütz GmbH

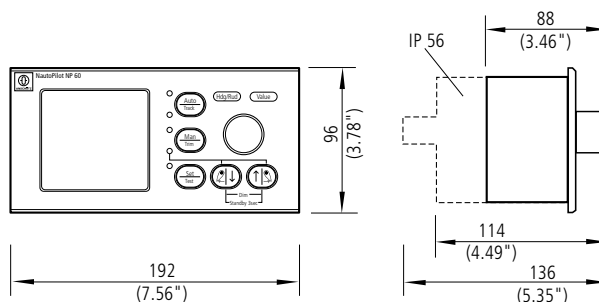

Operator unit 0.6 kg

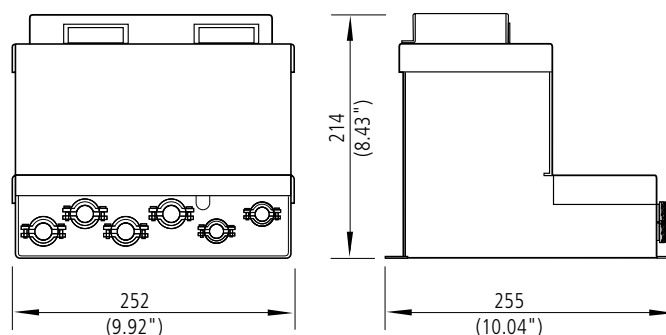

Connection unit 5.2 kg

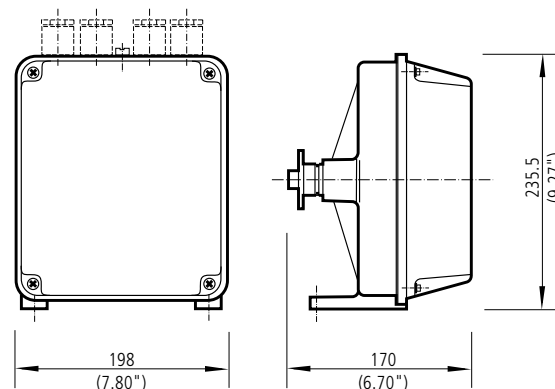

Feedback unit »heavy duty«

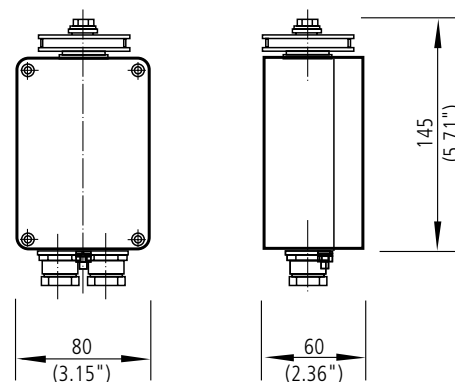

Feedback unit 0.9 kg

Subject to change due to technical developments without notice.

All rights reserved. Printed in Germany
RAN 60.057 e / L&S 0806

Raytheon Anschütz GmbH

D-24100 Kiel, Germany
Tel +49(0)4 31-30 19-0
Fax +49(0)4 31-30 19-291
Email sales@raykiel.com
www.raytheon-anschuetz.com